

ARTICLE 20: SIGNS

Section 20.01: Statement of Purpose

Section 20.02: Applicability – Effect

Section 20.03: Legal Non-Conforming Signs

Section 20.04: Computations for Signs

Section 20.05: Zoning District Sign Regulations

Section 20.06: Business/Commercial/Manufacturing/District Signs

Section 20.07: Interstate Business District (IB) Signs

Section 20.08: Sport Entertainment District Signs

Section 20.09: Agriculture and Residential District Signs

Section 20.10: Temporary Sign Requirements for All Districts

Section 20.11: General Requirements for All Signs

Section 20.12: Signs Exempt from the Regulations Contained in this Article

Section 20.13: Variance Standards for Signs

Section 20.14: Application for a Sign Variance

Section 20.15: Sign Permits

Section 20.01 Statement Of Purpose

The purpose of these sign regulations is to encourage the effective use of signs as a means of communication in the township; to maintain and enhance the aesthetic environment and the township's ability to attract sources of economic development and growth; to improve pedestrian and traffic safety; to provide for public health and safety by minimizing the possible adverse effect (including but not limited to the obstruction of sight distance to motorists entering and exiting a roadway and distracting motorists of signs on nearby public and private property; to control litter; to maintain property values; to maintain character of the community; and to enable the fair and consistent enforcement of these sign regulations. This sign resolution is adopted under the zoning authority of the township in furtherance of the more general purposes set forth in the zoning resolution.

Section 20.02 Applicability – Effect

A sign may be erected, placed, established, painted, created, or maintained in the township only in conformance with the standards, procedures, exemptions, and other requirements of this resolution.

Section 20.02.A

The effect of this resolution as more specifically set forth herein, is:

Section 20.02.A.1

To establish a permit system to allow a variety of types of signs in commercial and industrial zones, and a limited variety of signs in other zones, subject to the standards and the permit procedures of this resolution;

Section 20.02.A.2

To allow certain signs that are small, unobtrusive, and incidental to the principal use of the respective lots on which they are located, subject to the substantive requirements of this resolution, but without a requirement for permits;

Section 20.02.A.3

To prohibit all signs not expressly permitted by this resolution (unless amended by the process outlined in Article 6 of this resolution);

Section 20.02.A.4

And to provide for the enforcement of the provisions of this resolution.

Section 20.02.A.5

Applies only to exterior signs unless otherwise specified.

Section 20.03 Legal Nonconforming Signs

Any sign lawfully erected and in existence on the effective date of this resolution that does not meet the requirements of this resolution may be maintained as a matter of right as a legal nonconforming sign and may be rebuilt on the same property, in accordance to Article 3: Non-Conformities of this resolution, provided said sign's degree of nonconformity is not increased.

Section 20.04 Computations For Signs

Section 20.04.A

The following principles shall control the computation of sign area and sign height:

Section. 20.04.A.1 Computation of Area of Individual Signs

Section 20.04.A.1.a Computation of Area of Single-Faced Signs

The area of a sign (which is also the sign area of a wall sign or other sign with only one face) shall be computed by means of measuring the outer limits of the sign face, which includes the area of any square, circle, rectangle, triangle, or combination thereof that will encompass the extreme limits of the writing, graphic representation, emblem, or other display, together with any material or color forming an integral part of the background of the display or used to differentiate the sign face from the backdrop or structure against which it is placed. This shall not include any supporting framework, bracing, or decorative fence or wall when such fence or wall otherwise meets zoning resolution regulations and is clearly incidental to the display itself. The sign face may completely cover the structure or backdrop, in which case the entire structure would be included in the sign face computation. See also Figures Article 20-A through Article 20-C sign measurement graphics.

Section 20.04.A.1.b Computation of Area of Multi-faced Signs

The area for a sign with more than one face shall be computed as stated in Section 20.04.A.1.a: Computation of Area of Single Faced Sign for each face. Only one face shall be visible from any one point. For example, a two-sided sign, where face A is on the backside of face B, shall be measured as noted in Section 20.04.A.1.a: Computation of Area of Single Faced Sign for side A and side B separately. However, if a sign is multi-faced, where face A and face B are visible from a single point (such as stacked one above the other), then both face A and face B combined shall equal the area computation in Section 20.04.A.1.a: Computation of Area of Single Faced Sign.

Union Township
Zoning Resolution

Section 20.04.A.1.c Computation of Height

The height of a sign shall be computed as the distance from the base of the sign at normal grade to the top of the highest attached component of the sign. Normal grade shall be construed to be the lower of (1) existing grade prior to construction or (2) the newly established grade after construction, exclusive of any filling, berming, mounding, or excavating solely for the purpose of locating the sign. In cases where the normal grade cannot reasonably be determined, sign height shall be computed on the assumption that the elevation of the normal grade at the base of the sign is equal to the elevation of the nearest point of the crown of a public street, or the grade of the land at the principal entrance to the principal structure on the zone lot, whichever is lower.

Section 20.04.A.1.d Computation of Maximum Total Permitted Sign Area for a Zone Lot

The maximum sign area shall be the maximum area specified in Sections 20.05: Zoning District Sign Regulations, to Section 20.10: Temporary Sign Requirements For All Districts. Lots fronting on two or more streets are allowed the permitted sign area for each street frontage, excluding temporary signs and pole signs. However, the total sign area that is oriented toward a particular street may not exceed the portion of the lot's total sign area allocation that is derived from the lot, building, or wall area frontage on that street, unless otherwise specified.

Figure Article 20-A: SIGN FACE AND HEIGHT MEASUREMENTS

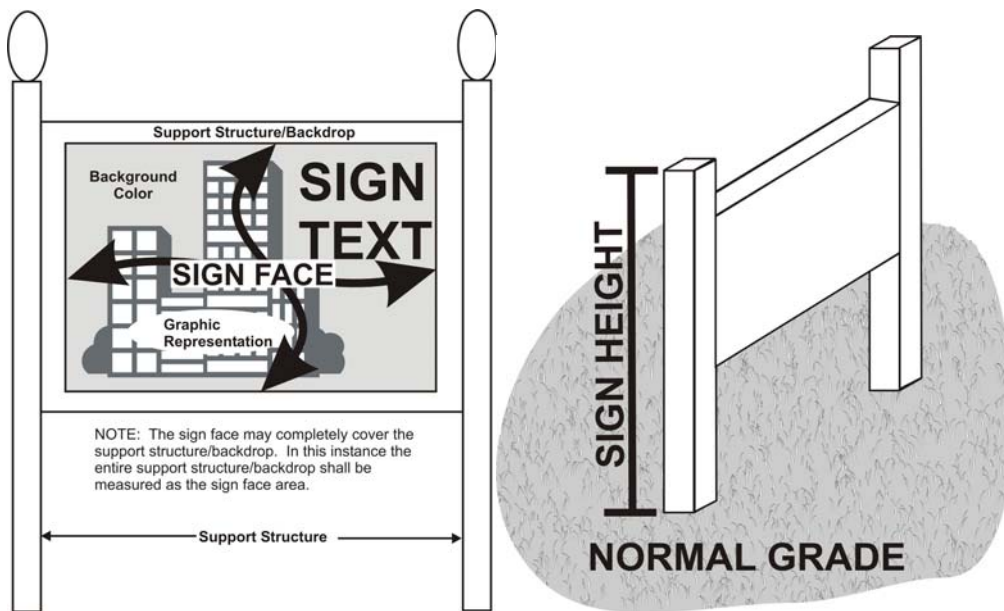

Union Township
Zoning Resolution

Figure Article 20-B: DIAGRAMS OF SIGN STRUCTURE COMPONENTS FOR VARIOUS TYPES OF SIGN STRUCTURES

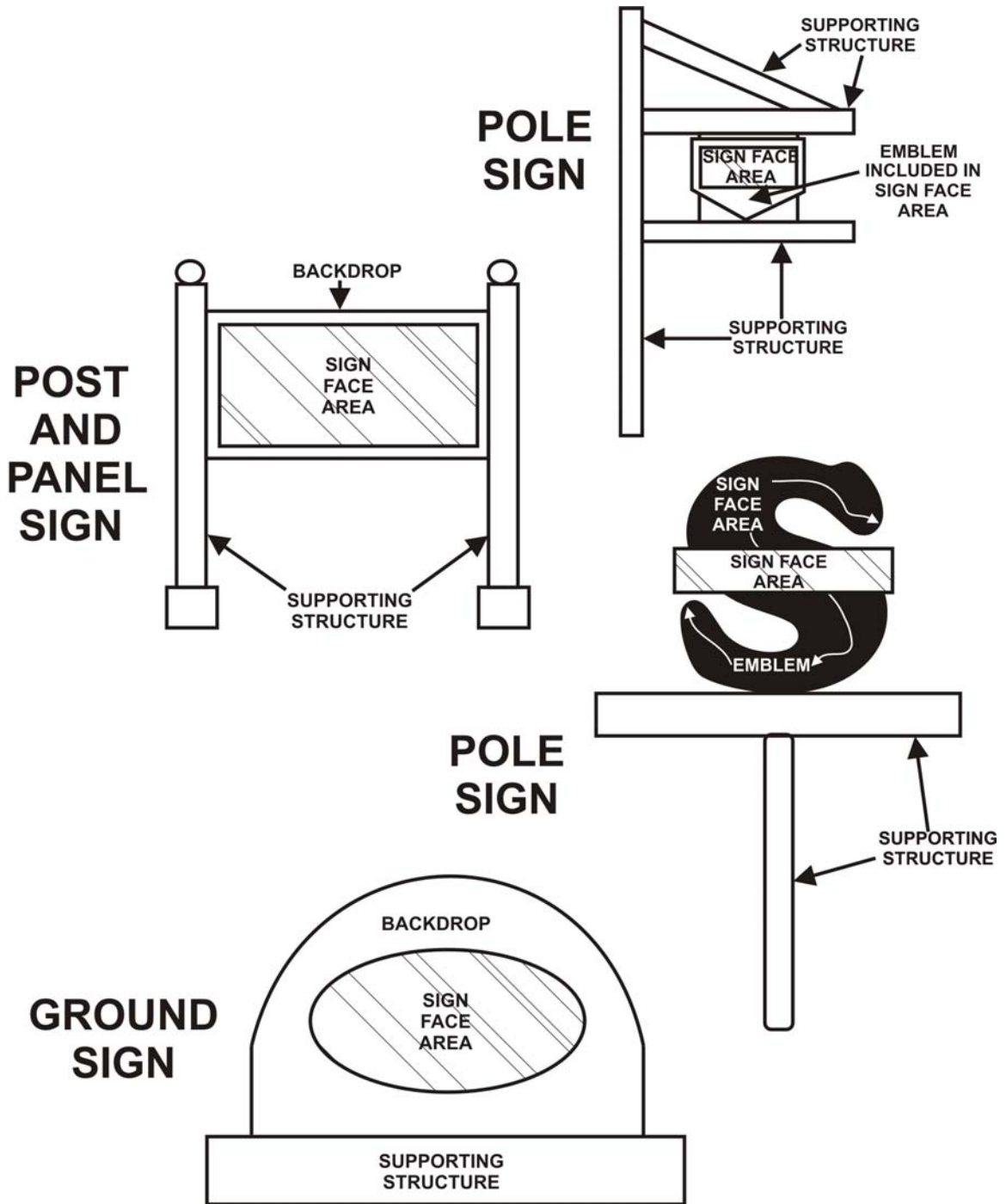
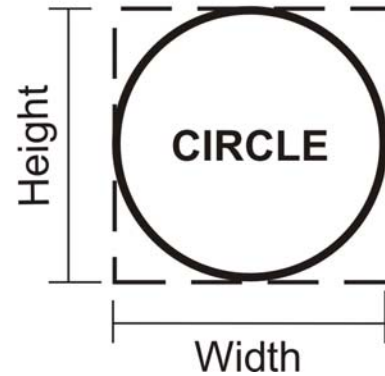
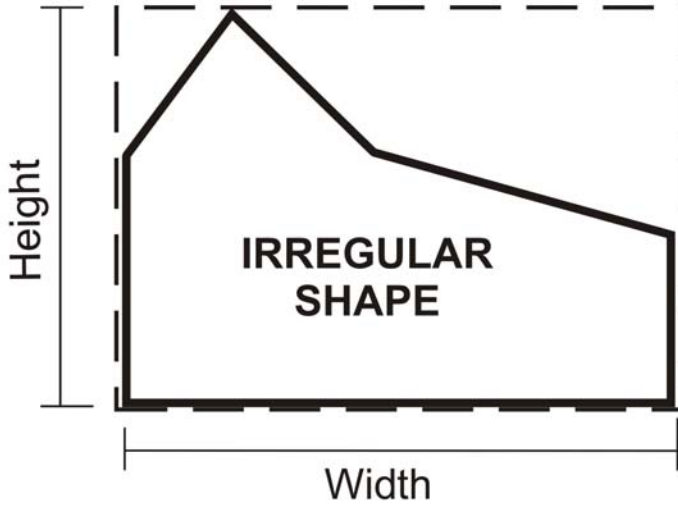
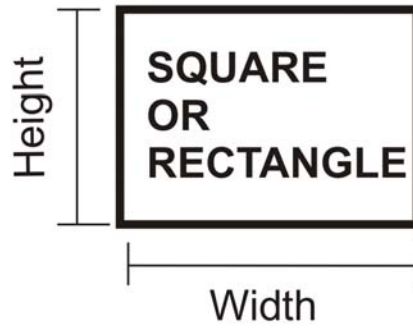
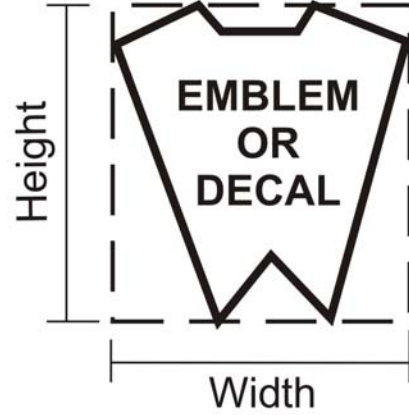
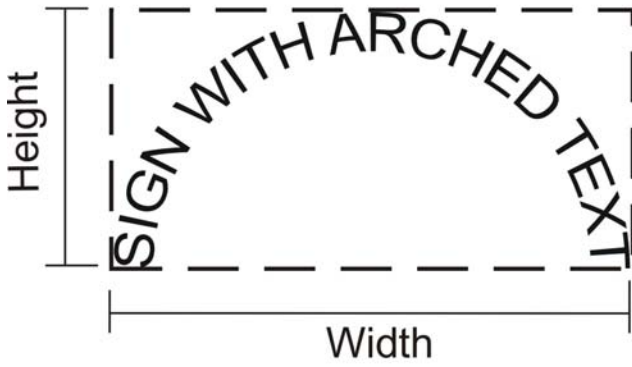

Figure Article 20-C: SIGN FACE MEASUREMENTS



Section 20.05 Zoning District Sign Regulations

Sign regulations are specified by zoning district as follows:

- Section 20.06: Business/Commercial/Manufacturing Districts Signs (excluding Interstate Business)
- Section 20.07: Interstate Business District Signs
- Section 20.08: Sport Entertainment District Signs
- Section 20.09: Agriculture and Residential District Signs

Section 20.06 Business/Commercial/Manufacturing District Signs *(Excluding Interstate Business District, which is otherwise regulated within this resolution)*

Section 20.06.A Business/Commercial/Manufacturing District On-Premise Signs Permitted, NO PERMIT REQUIRED

Section 20.06.A.1 Fuel Island Canopy Sign

A fuel island canopy sign means a sign attached to or part of a fuel island canopy. Such sign shall not extend beyond (in any direction) the façade of the canopy.

Section 20.06.A.2 Entrance and Exit Signs

Entrance and exit signs providing directional information may be permitted. Such signs shall not exceed a height of two and a half (2.5) feet and shall not have a sign area of three (3) square feet on any face. Entrance and exit signs shall not be located within the road right-of-way and shall not be placed in any manner that will impede a motorists visual line of sight and/or create a safety hazard to motorist or any pedestrian. Such signs may include a company logo, but shall not include any other advertising that will distract the driver's attention from the directional prompts or reduce the driver's reaction time thus negating the purpose for the sign and creating a safety hazard.

Section 20.06.A.3 On-Site Traffic Control Signs

On-site traffic control signs including but not limited to stop signs, yield signs, or other directional signs may be permitted. Such signs shall not be located within the road right-of-way and shall not be placed in any manner that will impede a motorist's visual line of sight and/or

Union Township
Zoning Resolution

create a safety hazard to a motorist or any pedestrian. Such signs may include a company logo but shall not include any other advertising that will distract the driver's attention from the traffic safety prompts or reduce the driver's reaction time thus negating the purpose of the sign and creating a safety hazard. Said signs shall not exceed a height of eight (8) feet .

Section 20.06.B Business/Commercial/Manufacturing District On-Premise Signs Permitted, PERMIT REQUIRED

Section 20.06.B.1 On-Premise Wall Signs

Each business shall be permitted one flat or wall on-premises sign. Projection of wall signs shall not exceed four (4) feet measured from the face of the main building, not more than ten (10) square feet on any one face of the sign.

Section 20.06.B.2 On-Premise Ground Sign

In addition to the above, each business or industry shall be permitted one on-premises ground sign, provided all parts of the sign shall be set back ten (10) feet from the street right-of-way. The maximum area of such sign shall not exceed thirty-two (32) square feet on any face of the sign. The sign must be permanently affixed to the ground and shall not exceed a height of six (6) feet.

Section 20.06.B.3 On-Premise Pole Sign

In addition to the above, each business or industry shall be permitted one on-premises pole sign not exceeding thirty (30) feet in height or fifty (50) square feet in area on any face (maximum of two [2] faces) of the sign. Such signs shall not be located closer than ten (10) feet from any road right-of-way line. The sign must be permanently affixed to the ground and shall not exceed a height of twenty (20) feet.

Section 20.06.B.4 Multiple Business Sign Alternatives

In lieu of the permitted pole sign as permitted in Section 20.06B.3: On-Premise Pole Sign above, groups of establishments of four or more business shall be permitted one larger ground sign for all businesses. Such sign shall not exceed eighty (80) square feet on any face nor exceed thirty (30) feet in height and shall be setback at least ten (10) feet from the road right-of-way. The sign must be permanently affixed to the ground and shall not exceed a height of twenty (20) feet.

**Section 20.06.C Business/Commercial/Manufacturing
District OFF-Premise Signs Permitted, PERMIT REQUIRED**

Section 20.06.C.1 Billboards

Section 20.06.C.1.a General

Billboards shall be classified as a business use and be permitted in all Business, Commercial and Manufacturing districts subject to the following regulations:

Section 20.06.C.1.b Setback from Right-Of-Way

Such signs or structures shall not be located within seventy-five (75) feet of any street (or road) right-of-way.

Section 20.06.C.1.c Spacing

Such signs or structures shall not be located within three-thousand (3,000) feet of any other billboard

Section 20.06.C.1.d Sign Setback from Structures

Such signs or structures shall not be located on or within one-hundred (100) feet of any building or other sign.

Section 20.06.C.1.e Sign Face Area

Such signs shall not exceed three-hundred (300) square feet on one face and/or six-hundred (600) square feet for two or more faces, and in no case shall more than three-hundred (300) square feet of display or sign area be visible from any road or street.

Section 20.06.C.1.f Sign Height

No billboard sign shall exceed a height of twenty-six (26) feet.

Section 20.06.C.1.g Relation to Other Laws

Advertising devices adjacent to the interstate and primary highways as regulated by the Ohio Revised Code, Section 5516.01 to 5516.13 and 5531.07, as amended shall be permitted in accordance with those state laws. The Zoning Inspector shall only issue a permit when the applicant produces a permit from the State, and the proposed meets the requirements of this Article.

Section 20.07 Interstate Business District (IB) Signs

Section 20.07.A IB District On-Premise Signs Permitted, NO PERMIT REQUIRED.

Section 20.07.A.1 Entrance and Exit Signs

Entrance and exit signs providing directional information may be permitted. Such signs shall not exceed a height of two and a half (2.5) feet and shall not have a sign area of three (3) square feet on any face. Entrance and exit signs shall not be located within the road right-of-way and shall not be placed in any manner that will impede a motorists visual line of sight and/or create a safety hazard to a motorist or any pedestrian. Such signs may include a company logo but shall not include any other advertising that will distract the driver's attention from the directional prompts or reduce the driver's reaction time thus negating the purpose for the sign and creating a safety hazard.

Section 20.07.A.2 On-Site Traffic Control Signs

On-site traffic control signs including but not limited to stop signs, yield signs, or other directional signs may be permitted. Such signs shall not be located within the road right-of-way and shall not be placed in any manner that will impede a motorist's visual line of sight and/or create a safety hazard to a motorist or any pedestrian. Such signs may include a company logo but shall not include any other advertising that will distract the driver's attention from the traffic safety prompts or reduce the drivers reaction time thus negating the purpose of the sign and creating a safety hazard. Said signs shall not exceed a height of eight (8) feet .

Section 20.07.B IB District On-Premise Signs Permitted, PERMIT REQUIRED

Section 20.07.B.1 On-Premise Wall Signs

Each business shall be permitted one flat or wall on-premises sign. Projection of wall signs shall not exceed four (4) feet measured from the face of the main building, not more than ten (10) square feet on any one face of the sign.

Section 20.07.B.2 On-Premise Ground Sign

In addition to the above, each business or industry shall be permitted one on-premises ground sign, provided all parts of the sign shall be set back ten (10) feet from the road right-of-way. The maximum area of such sign shall not exceed thirty-two (32) square feet on any face of

Union Township
Zoning Resolution

the sign. The sign must be permanently affixed to the ground and shall not exceed a height of six (6) feet.

Section 20.07.B.3 On-Premise Interstate Pole Sign (High-Rise Pole Sign)

In addition to the above, each business located adjacent to or within one-thousand (1,000) feet of the midpoint of the intersection of an Interstate. Currently this includes the intersection of Interstate 70 and State Route 37, and the intersection of Interstate 70 and State Route 79. These intersections shall be permitted one on premises pole sign not exceeding seventy-five (75) feet in height or eighty (80) square feet in area on any face of the sign. Such signs shall be located no closer than $\frac{1}{2}$ the total sign height or a minimum of twenty (20) feet, whichever is greater, from any right-of-way line. The purpose of said sign shall be to inform and attract motorists from Interstate 70, therefore said sign shall be oriented to Interstate 70. The sign must be permanently affixed to the ground.

Section 20.07.B.4 On-Premise Pole Sign

In place of the on-premise interstate pole sign (high-rise pole sign), each business or industry may be permitted one on-premises pole sign not exceeding thirty (30) feet in height or fifty (50) square feet in area on any face of the sign. Such signs shall not be located closer than twenty (10) feet from any road right-of-way line. No sign shall exceed one-hundred (100) total square feet of sign face area. The sign must be permanently affixed to the ground and shall not exceed a height of twenty (20) feet.

Section 20.07.B.5 Multiple Business Sign Alternatives

In lieu of the permitted on-premise interstate pole sign or on-premise pole sign as permitted in Section 20.07.B.3: On-Premise Interstate Pole Sign or Section 20.07.B.4: On-Premise Pole Sign above, groups of establishments of four or more business shall be permitted one larger ground sign for all businesses. Such sign shall not exceed eighty (80) square feet on any face, nor exceed thirty (30) feet in height, and shall be setback at least twenty (20) feet from the road right-of-way. The sign must be permanently affixed to the ground and shall not exceed a height of twenty (20) feet.

Section 20.07.B.6 Fuel Island Canopy Sign

A fuel island canopy sign means a sign attached to or part of a fuel island canopy. Such signs shall not extend beyond (in any direction) the façade of the canopy.

**Section 20.07.C Interstate Business District OFF-Premise
Signs Permitted, PERMIT REQUIRED**

Section 20.07.C.1 Billboards

Section 20.07.C.1.a General

Billboards shall be classified as a business use and be permitted in all Interstate Business Districts subject to the following regulations:

Section 20.07.C.1.b Setback From Right-Of-Way

Such signs or structures shall not be located within fifty (50) feet from any road right-of-way.

Section 20.07.C.1.c Spacing

Such signs or structures shall not be located within three-thousand (3000) feet of any other billboard.

Section 20.07.C.1.d Sign Setback from Structures

Such signs or structures shall not be located on or within one-hundred (100) feet of any building or other sign.

Section 20.07.C.1.e Sign Face Area

Such signs or structures shall not be located on or within three-hundred (300) square feet on one face and/or six-hundred (600) square feet for two or more faces, and in no case shall more than three-hundred (300) square feet of display or sign area be visible from any road or street.

Section 20.06.C.1.f Sign Height

No billboard sign shall exceed a height of twenty-six (26) feet.

Section 20.06.C.1.g Relation to Other Laws

Advertising devices adjacent to the interstate and primary highways as regulated by the Ohio Revised Code, Section 5516.01 to 5516.13 and 5531.07, as amended shall be permitted in accordance with those state laws. The zoning inspector shall only issue a permit when the applicant produces a permit from the State, and the proposed meets the requirements of this Article.

Section 20.08 Sport Entertainment District Signs

Section 20.08.A Sport Entertainment District On Premise Signs Permitted, NO PERMIT REQUIRED

Section 20.08.A.1 Inner Track/Field/Court/Stadium Signs

As the majority of sport entertainment facilities are outdoor facilities, the inner track/field/court/stadium signs shall be defined as those signs located within and directed towards the concession, food court, bleacher/seating, pathways, playing, and restroom facility areas of the professional sport entertainment facility. Any signs directed toward the public or private road right-of-way or adjoining lot of record shall comply with the regulations herein.

Section 20.08.A.2 Gate/Entrance and Exit Signs

Gate/entrance and exit signs providing directional information may be permitted. Such signs shall not exceed a height of fifteen (15) feet and shall not have a sign area greater than fifty (50) square feet on any face. Gate/entrance and exit signs shall not be located within the road right-of-way and shall not be placed in any manner that will impede a motorist's visual line of sight and/or create a safety hazard to a motorist or any pedestrian. Such signs may include a company logo but shall not include advertising that will distract the driver's attention from the directional prompts thus negating the purpose of the sign and creating a safety hazard. These signs are generally larger than other business entrance and exit signs due to the nature of these events. Said events generally attract large crowds and large volumes of traffic over a short period of time. Patrons generally have tickets or passes for specific entrance gates. Therefore, it is important to have larger signs, which may be viewed from a greater distance in order for patrons to locate and maneuver in a safe and timely manner into the appropriate traffic lanes to access these specified gates.

Section 20.08.A.3 On-Site Traffic Control Signs

On-site traffic control signs including but not limited to stop signs, yield signs, or other directional signs may be permitted. Such signs shall not be located within the road right-of-way and shall not be placed in any manner that will impede a motorist visual line of sight and/or create a safety hazard to the motorist or any pedestrian. Such signs may include a company logo but shall not include advertising that will distract the driver's attention from the traffic safety prompts thus negating the purpose of the sign and creating a safety hazard. Said signs shall not exceed a height of eight (8) feet .

**Section 20.08.B Professional Sport Entertainment District
On Premise Signs Permitted, PERMIT REQUIRED**

Section 20.08.B.1 On-Premise Wall Signs

Each business shall be permitted one flat (flush mounted) on-premise wall sign or one projecting on-premise wall sign. No sign face area of said sign shall be greater than five (5) percent of the façade it is located on, and no sign shall extend beyond one (1) foot from the face of said façade. The one (1) foot standard within this section shall supercede the four (4) foot standards in **Section 20.11.B.4: Projecting Wall Signs**.

Figure Article 20-E: On-Premise Wall Signs Flat vs. Projecting

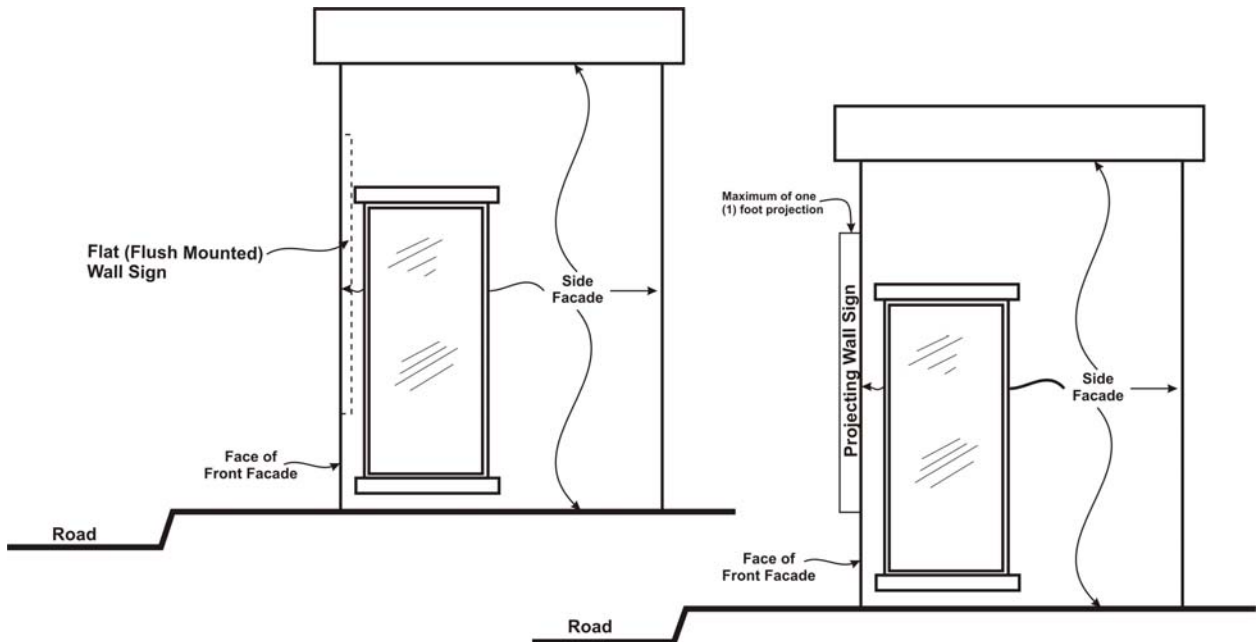

Section 20.08.B.2 On-Premise Ground Sign

In addition to the above, each business or industry shall be permitted one on-premises ground sign, provided all parts of the sign shall be set back ten (10) feet from the road right-of-way. The maximum area of such sign shall not exceed thirty-two (32) square feet on any face of the sign. The sign must be permanently affixed to the ground and shall not exceed a height of six (6) feet.

**Section 20.08.C Sport Entertainment District Off Premise
Temporary Sign PERMIT REQUIRED**

Up to four off-premise temporary signs shall be permitted, with a maximum sign face area of twenty-four (24) sq. ft. Said signs may be installed for a period of seven (7) days and shall be removed one day after the event or purpose for which they are established. The zoning inspector is hereby granted the authority to issue a zoning sign permit for a calendar year for temporary signs in this district that are reoccurring. The applicant shall provide a list of all dates the signs shall be erected and the dates the signs shall be removed for a calendar year. Any variation from the schedule submitted to the zoning inspector shall require a separate permit.

Section 20.09 Agriculture And Residential District Signs

Section 20.09.A Agriculture and Residential District On-Premise Signs Permitted, NO PERMIT REQUIRED

Reserved for future use.

Section 20.09.B Agriculture and Residential District On-Premise Signs Permitted, PERMIT REQUIRED

Section 20.09.B.1 On-Premise Ground Signs Residential District/Use

One on-premise ground sign shall be permitted in any residential district or on any property with a residential use within an agriculture district or residential district. Said sign shall be set back ten (10) feet from the road right-of-way line or any lot line, and shall have a maximum of two sign faces; no single face shall have an area greater than six (6) square feet.

Platted residential developments shall be permitted up to two ground signs in accordance with Section 20.09.B.2: On-Premise Ground Sign Agriculture District/Use or Non-Residential Use at the entrance to said development. This shall be independent of any sign permitted in accordance with this subsection on any individual lot of record within the platted residential development.

Union Township
Zoning Resolution

Section 20.09.B.2 On Premise Ground Sign Agriculture District/Use or Non Residential Use

Any agricultural or non-residential use within any agricultural district shall be permitted one on-premise ground sign, provided all parts of the sign shall be set back ten (10) feet from the road right-of-way line and any lot line. The maximum area of such sign shall not exceed thirty-two (32) square feet on any face of the sign. The sign must be permanently affixed to the ground. Additionally, any platted residential development shall be permitted one On-Premise Ground Sign at each entrance to the development in accordance with the standards stated within this subsection. Please note a boulevard road shall be considered one entrance for the purpose of determining the number of signs permitted within this subsection.

Section 20.09.C Agriculture District OFF-Premise Signs Permitted, PERMIT REQUIRED

Section 20.09.C.1 Billboards

Section 20.09.C.1.a General

Billboards shall be classified as a business use and shall be permitted in all Agriculture districts subject to the following regulations:

Section 20.09.C.1.b Setback From Right-Of-Way

Such signs or structures shall not be located fifty (50) feet of any street (or road) right-of-way.

Section 20.09.C.1.c Spacing

Such signs or structures shall not be located within three-thousand (3,000) feet of any billboard.

Section 20.09.C.1.d Sign Setback from Structures

Such signs or structures shall not be located on or within one-hundred (100) feet of any building or other sign.

Section 20.09.C.1.e Sign Face Area

Such signs or structures shall not be located on or within three-hundred (300) square feet on one face and/or six-hundred (600) square feet for two or more faces, and in no case shall more than three-hundred (300) square feet of display or sign area be visible from any road or street.

Section 20.06.C.1.f Sign Height

No billboard sign shall exceed a height of twenty-six (26) feet.

Union Township
Zoning Resolution

Section 20.06.C.1.g Relation to Other Laws

Advertising devices adjacent to the interstate and primary highways as regulated by the Ohio Revised Code, Section 5516.01 to 5516.13 and 5531.07, as amended shall be permitted in accordance with those state laws. The zoning inspector shall only issue a permit when the applicant produces a permit from the State, and the proposed meets the requirements of this Article.

Section 20.09.C.1.h Prohibited

Billboards shall not be permitted in any platted residential area within the agricultural district.

Section 20.10 Temporary Sign Requirements For All Districts

Section 20.10.A General

Temporary signs are permitted with a temporary sign permit unless specified exempt. Such signs shall conform to the requirements set forth below as well as other applicable requirements of this resolution.

Section 20.10.B Standards For All Temporary Signs

Temporary signs specified in this Article shall not be attached to fences, trees, utility poles, or the like and shall not be placed in a position that will obstruct or impair vision of motorists or pedestrians, or in any manner create a hazard or disturbance to the health, safety and welfare of the general public.

Section 20.10.C Temporary Sign Component Materials

Temporary signs shall be post and panel sign construction. A post and panel sign is constructed of either wood post or metal post (not wire frames) that provide support at each side of the sign. The sign face shall be constructed of wood, metal, or corrugated polycarbonate. Said sign face shall be substantially secured to the support post by being nailed, screwed, or bolted to the supporting wood or metal post. No sign shall be stapled, taped, tied, or fastened by plastic or metal ties or the like.

Section 20.10.D Applicant for Temporary Sign

The applicant for a Temporary Sign shall be the owner of the business placing the sign and the owner of the lot upon which the sign shall be located (if different than the owner of the business). Both individuals shall sign the application and shall accept the responsibility of ensuring said

Union Township
Zoning Resolution

sign is established, maintained, and removed in accordance with the rules and procedures herein and in a manner that is aesthetically pleasing and will not adversely impact the health, safety or welfare of the general public.

Section 20.10.E Application and Expiration of Temporary Sign Permits

Application for a temporary sign permit shall follow the requirements outlined in Section 20.10.D: Applicant for Temporary Sign. The permit shall specify the dates during which the sign will be displayed and will expire at the end of the calendar day on the last date so specified.

Section 20.10.F Removal of Temporary Signs

All temporary signs shall be removed within four (4) days of the expiration of the temporary sign permit.

**Section 20.10.G Temporary Signs Permitted in Any District
NO PERMIT REQUIRED**

Section 20.10.G.1 Temporary On-Premise Signs Not To Exceed Four (4) Square Feet of Sign Face

Temporary on-premise signs not to exceed four (4) square feet of sign face shall be permitted in any district. Said signs shall be removed within four (4) days from the conclusion of said event or purpose for which the temporary sign is established.

Section 20.10.G.1.a Sign Face Measurement

Temporary signs not exceeding four (4) square feet of sign face for a single-sided sign and eight (8) square feet (four [4] square feet per sign face) for a two-sided sign shall be permitted in any district.

Section 20.10.G.1.b Sign Setback

Temporary signs shall maintain a ten (10) foot setback from any lot line and road right-of-way line. Where no road right-of-way exists, the setback shall be forty (40) feet from the centerline of the road.

Section 20.10.G.1.c Sign Placement

Temporary signs may be placed on the ground or attached to a structure only in locations where a wall sign or roof sign would be permitted and does not exist. No temporary sign shall be placed upon any pole, upon any fence, gate, wall, or within any road right-of-way.

Union Township
Zoning Resolution

Section 20.10.G.1.d Number signs permitted

The number of temporary signs permitted shall not exceed one sign per two-hundred (200) feet of road frontage with a maximum of four temporary signs permitted per lot of record.

Section 20.10.H Temporary Signs Permitted in any Business, Commercial, Manufacturing, or Agricultural District PERMIT REQUIRED

Section 20.10.H.1 Temporary On-Premise Signs

Temporary on-premise signs greater than eight (8) square feet of sign face but less than sixteen (16) square feet may be permitted in any Business, Commercial, Manufacturing, or Agricultural Zoning District upon receiving and maintaining a valid zoning permit. Said signs may include but are not limited to signs announcing a special event, sales event signs, seasonal sales and the like. No temporary sign under this subsection shall be permitted for a period of time greater than three (3) months.

Section 20.10.H.2 Temporary Off-Premise Signs

Temporary off-premise signs not exceeding six (6) square feet of sign face for a single sided sign and twelve (12) square feet (six [6] square feet per sign face) for a two sided sign may be permitted in any Business, Commercial, Manufacturing or Agricultural District upon receiving and maintaining a valid zoning permit. No temporary sign under this subsection shall be permitted for a period of time greater than three (3) months.

Section 20.10.I Temporary Sign Requirements

Section 20.10.I.1 Sign Setback

Temporary signs shall maintain a ten (10) foot setback from any lot line and road right-of-way line. Where no road right-of-way exists the setback shall be forty (40) feet from the centerline of the road.

Section 20.10.I.2 Annual Installation of Signs for more than one business on a parcel

Where a single lot contains more than one but less than seven businesses, the number of annual installations shall be calculated separately for each business, but only one Temporary Business Sign may be displayed on the lot at any one time. Where a single lot contains seven or more businesses, the number of annual installations shall be calculated separately for each business, but only two Temporary Business Signs may be displayed on the lot at any one time and only if the signs are at least 100 feet apart. The zoning

Union Township
Zoning Resolution

inspector shall act upon any multiple applications for Temporary Business Signs on a single lot on a first-come, first-served basis according to the dates and times of receipt of the applications.

Section 20.10.I.3 Prohibition of Temporary Signs

No Temporary Business, Commercial, Manufacturing, or Agricultural sign shall be allowed on any lot that is occupied by a single business or two or more businesses in which a reader board incorporated into a permanent freestanding sign is established upon the sight.

Section 20.10.I.4 Quantity Permitted

In regards to off-premise temporary signs, a property owner is permitted up to ten (10) temporary signs per permit obtained. Such sign(s) shall not be located closer than two-hundred (200) feet from any other sign promoting said event or message.

Section 20.11 General Requirements For All Signs

Section 20.11.A Limitation of Advertising Devices Along State Primary Highways

Section 20.11.A.1 Signs adjacent to Interstate/Primary Highways

Larger signs or advertising devices for businesses or industries adjacent to the interstate and primary highway as regulated by the Ohio Revised Code, Chapter 5516, as amended shall be permitted in accordance with those state laws in addition to the requirements of the Union Township Zoning Resolution. Such signs shall require a permit from the township zoning inspector. The owner or agent of such sign must show proof of having obtained the required State of Ohio approval prior to the township zoning Inspector issuing a permit.

Section 20.11.A.2 Placement of Signs

No advertising device shall be erected or maintained within six hundred sixty (660) feet of the edge of the right-of-way of a highway on the primary system as defined by the State of Ohio under Section 5516.06 of the Ohio Revised Code, except the following:

Section 20.11.A.2.a Directional and Official Signs

Directional and other official signs and notices that conform to rules adopted by the director of the Ohio Department of Transportation;

Union Township
Zoning Resolution

Section 20.11.A.2.b Signs advertising Sale or Lease

Signs advertising the sale or lease of the property upon which they are located;

Section 20.11.A.2.c Signs identifying the property

Advertising devices indicating the name of the business, activities, or profession conducted on such property or that identify the goods produced, sold, or services rendered on such property and that conform to rules adopted by the director of the Ohio Department of Transportation;

Section 20.11.A.2.d Precautionary Signs

Precautionary signs relating to the premises;

Section 20.11.A.2.e Location, Identification and Warning Signs

Signs, displays, or devices that locate, identify, mark, or warn of the presence of pipelines, utility lines, or rail lines, and appurtenances thereof, including, but not limited to, markers used in the maintenance, operation, observation, and safety of said lines;

Section 20.11.A.2.f General

Advertising devices located in zoned industrial or commercial areas adjacent to highways on the primary system that conform to rules adopted by the director of the Ohio Department of Transportation;

Section 20.11.A.2.g Lawfully Existing Signs

Signs lawfully in existence on Oct. 22, 1965, that the director, subject to the approval of the secretary of the United States Department of Transportation, has determined to be landmark signs, including signs on farm structures or natural surfaces, which are of historic or artistic significance;

Section 20.11.A.2.h Sports Facilities

Advertising devices that are located on the premises of a professional sports facility and that conform to rules adopted by the director of the Ohio Department of Transportation.

Section 20.11.B General Sign Requirements for All Districts

The regulations contained in this section shall apply all signs and all use districts.

Section 20.11.B.1 All signs shall be constructed of durable materials, anchored to the ground or principal structure as permitted by the regulations herein, and braced so that the sign will not sway, flap, or

Union Township
Zoning Resolution

otherwise move or be blown out. Signs shall be post and panel sign construction. A post and panel sign is constructed of either wood post or metal post (not wire frames) that provide support at each side of the sign. The sign face shall be constructed of wood, metal, or corrugated polycarbonate. Said sign face shall be substantially secured to the support post by being nailed, screwed, or bolted to the supporting wood or metal post. No sign shall be stapled, taped, tied, or fastened by plastic or metal ties or the like. No temporary sign shall be converted to a permanent sign by simply anchoring it to the ground.

Section 20.11.B.2 Any illuminated sign or lighting device shall employ only light emitting a light of constant intensity with fully shielded fixtures so as to prevent light trespass and distraction. No sign shall be illuminated by or contain flashing, intermittent, rotating, or moving light or lights. In no event shall an illuminated sign or lighting device be placed or directed so as to permit the beams and illumination there from to be directed or beamed upon a public thoroughfare, highway, sidewalk, or adjacent premises so as to cause glare or reflection that may constitute a traffic hazard or nuisance.

Section 20.11.B.3 All wiring, fittings, and materials used in the construction, connection, and operation of electrically illuminated signs shall be in accordance with the provisions of the Local or State Electric Code.

Section 20.11.B.4 No projecting sign shall be erected or maintained that extends from the front or face of a building a distance of more than four (4) feet, including those projecting from the face of any theater, hotel, or motel marquee unless otherwise specified herein. No portable or temporary sign shall be placed on the front or face of a building or on any premises unless otherwise permitted herein.

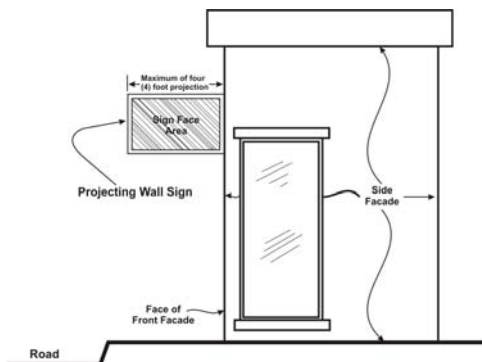

Section 20.11.B.5 No sign or part thereof shall contain or consist of banners, posters, pennants, ribbons, streamers, spinners, or other similar moving devices. Such devices, as well as strings of lights, shall

Union Township
Zoning Resolution

not be used for the purpose of advertising or attracting attention to a sign.

Section 20.11.B.6 No sign of any classification shall be installed, erected, or attached in any form, shape, or manner to a fire escape or any door or window giving access to any fire escape.

Section 20.11.B.7 Should any sign be or become unsafe or be in danger of falling or structurally failing, the owner thereof or the person maintaining the same shall upon receipt of written notice from the zoning inspector proceed at once to put such sign in a safe and secure condition or remove the sign.

Section 20.11.B.8 No sign shall be placed in any public right-of-way except publicly owned signs, such as traffic control signs and directional signs as required by law.

Section 20.11.B.9 All off-premises advertising devices erected or maintained under Chapter 5516.10 of the Ohio Revised Code shall be in compliance with Chapter 5516.10 and this resolution.

Section 20.11.B.10 No sign shall be located any closer than ten (10) feet from any public road right-of-way or property line, unless otherwise specifically stated herein. If a larger setback standard is required herein, said standard shall apply.

Section 20.11.B.11 Digital Signs

Digital signs are signs that display static images controlled by electronic communications. Any digital sign located within Union Township shall comply with the following regulations:

Section 20.11.B.11.a Minimum Message Display Duration (Message On-Time)

The minimum time that a message shall be displayed/remain fixed shall be 10 seconds.

Section 20.11.B.11.b Interval Between Successive Displays

When a message or copy changes it shall be accomplished in one (1) second or less.

Section 20.11.B.11.c Default Freeze

Said sign shall contain a default design that will freeze the device in one position (single advertisement) should the device malfunction.

Union Township
Zoning Resolution

Section 20.11.B.11.d Light Levels

Digital signs shall adjust brightness in response to changes in ambient light levels so that the signs remain at no more than 0.3-foot candles above the level of surrounding ambient light conditions. No digital sign shall cause glare onto any adjoining lot of record upon any horizontal or vertical plane on said adjoining lot of record.

Section 20.11.B.11.e Setback from Residential Structures

All digital signs shall have a setback of 2000 feet from any residential structure.

Section 20.11.C Signs Prohibited

All signs not expressly permitted under this resolution or exempt from regulation hereunder in accordance with the previous sections are prohibited in Union Township. Such signs include, but are not limited to:

Section 20.11.C.1 Beacons;

Section 20.11.C.2 The Use of Flags and Pennants for Advertising
For the purpose of this section, the following flags and pennants shall not be considered advertising medium: The flag for the United States of America and any other flag for a nation; state flags, school, college or university flags, sport team flags/pennants, corporate flags, and the like. These flags and pennants are exempted because they are generally attached to flag poles and structures that are anchored to the ground or a structure and have hardware that secures them to these structures. Additionally, they generally have rules, traditions and are respected in such a way that they are maintained and do not contribute to litter, visual clutter, or create safety hazards. An example of the use of a flag or pennant as an advertising medium would be a flag or pennant advertising a product, event, sale, displaying a message, or the like. The purpose of regulating flags and pennants is to support the purpose and intent of this article by prohibiting flags and pennants that are stuck into the ground or attached to building overhangs, canopies, fences, and the like and often are blown around and contribute to litter, visual clutter, and impede motorists line of sight as they enter and exit public roadways. These types of flags and pennants are generally considered disposable and are not highly regarded and often are ignored by those establishing them and not maintained.

Section 20.11.C.3 Strings of lights not permanently mounted to a rigid background, except those exempt under the previous section.

Union Township
Zoning Resolution

Section 20.11.C.4 The parking of vehicles with signage affixed to or resting upon the vehicle in a manner as to act as a advertising medium for the premises upon which it is parked. See also Section 20.11.C.9.

Section 20.11.C.4.1 In regards to Section 20.11.C.4 above, a vehicle with advertising upon it shall be identified as being used in this manner when any of the following apply:

Section 20.11.7.C.4.1.a Said vehicle is located in a location for an extended period of time during a business day (a business day shall be deemed as normal or posted business operating hours, and repeatedly over two or more business days). Said business days shall not be required to be consecutive for the purpose of this section.

Section 20.11.C.4.1.b Said vehicle is parked or positioned in a manner as to present the face of the advertising message to motorist or pedestrians.

Section 20.11.C.4.1.c Said vehicle has a sign resting in the bed of a truck, on a roof top, or hood of a vehicle and/or has a sign strapped to the vehicle by means of a rope, chain, bungee cord, and the like.

Section 20.11.C.5 Advertising devices erected or maintained on trees, or painted or drawn upon rocks or other natural features.

Section 20.11.C.6 Advertising devices, which prevent the driver of a vehicle from having a clear and unobstructed view of official signs (traffic control signs, directional signs, etc.) and approaching or merging traffic.

Section 20.11.C.7 Advertising devices illuminated so as to interfere with the effectiveness of or obscure an official sign, signs, or device.

Section 20.11.C.8 Advertising devices such as portable changeable copy signs.

Section 20.11.C.9 Signs and/or banners placed on semi trailers, buses, motor vehicles parked on a premise for the purpose of advertising. This does not include vehicles with company names that belong to a company being used on a daily basis and does not include vehicles that are patrons of a business which are at the business for less than twenty-four hours. This type of signage is strictly prohibited in any district. See also Section 20.11.C.4

Union Township
Zoning Resolution

Section 20.11.C.10 Advertising devices that attempt or appear to attempt to direct the movement of traffic or which interfere with imitate or resemble an official sign, signal, or device.

Section 20.11.C.11 No sign shall be placed within a road right-of-way or allowed to encroach upon a road right-of-way unless otherwise specified within this article. No person shall stand within the road right-of-way to act as an advertising medium. This includes hand held signs and sandwich board signs that are held or worn by an individual standing in the road right-of-way.

Section 20.11.C.12 Signs that are sexually oriented, explicit, obscene, or suggestive shall not be permitted within Union Township. See also Article 17: Adult Entertainment Regulations of this resolution.

Section 20.11.C.13 Inflatable signs.

Section 20.11.C.14 Any sign not expressly permitted shall be prohibited, unless added to this resolution as a permitted or conditionally permitted use in accordance with Article 5: Amendment of this resolution.

Section 20.12 Signs Exempt From The Regulations Contained In This Article

Section 20.12.A Regulatory Signs

Government agencies shall attempt to comply with these regulations but will be exempt if valid attempts fail and compliance would unreasonably inhibit or significantly hinder the public purpose.

For the purpose of this resolution, signs erected and maintained pursuant to and in discharge of any governmental function required by any law, resolution, ordinance, or governmental regulation, shall be exempt from these regulations.

Section 20.12.B Indoor and Enclosed Area Signs

For the purpose of this resolution, any sign that is indoor or in an outdoor area that is enclosed and not visible from any public road, road right-of-way, or any adjoining or nearby lot of record shall not be subject to the regulations herein. An enclosed area shall be defined as an outdoor area surrounded on all sides by a 100% opaque fence, wall or landscape buffer. Said opaque fence, wall, or landscape buffer shall comply with all applicable standards within this resolution.

Section 20.12.C Agriculture “Farm Market” Signs

For the purpose of this resolution, any sign that is used for “farm markets” shall be exempt from these regulations in accordance with Section 519.21(C) of the Ohio Revised Code. A farm market for the purpose of this resolution shall be any farm market where 50% or more of the gross income received from the market be derived from produce raised on lands owned or operated by the market operator in a normal crop year. This includes events that market the farm market in conjunction with its operation and are secondary to the production and sale of agriculture produce raised on lands owned or operated by the market operator in a normal crop year. This exemption does not exempt farm markets from complying with regulations for yard setback, size and height of the sign face and structure.

Section 20.13 Variance Standards For Signs

Section 20.13.A Standards

A variance from any requirement within Article 20: Signs is customarily not granted to increase the number of signs permitted by this Article. A variance from any requirement within Article 20: Signs shall only be considered when a practical difficulty pursuant to Section 4.11.B Area Variance of this resolution and any one or more of the circumstances listed below is present.

Section 20.13.A.1 Visibility by Motorist Due to Obstruction

Permitted signage cannot be easily seen by passing motorists due to the configuration of existing buildings, trees or other obstructions.

Section 20.13.A.2 Visibility by Motorist Due to Topography and Road Course

Permitted signage cannot be easily seen by passing motorists due to the topography of the land, or course of the road (i.e. sharp curve, hilly, or winding roadway).

Section 20.13.A.3 Visibility by Motorists Due to Speed

Permitted signage could not be seen by passing motorists in sufficient time to permit safe deceleration and exit. In determining whether such circumstances exist, the width of the road, the number of moving lanes, the volume of traffic and speed limits should all be taken into consideration.

Union Township
Zoning Resolution

Section 20.13.A.4 Obstruction by Physical Element

Existing signs on nearby parcels would substantially reduce the visibility or advertising impact of a conforming sign on the subject parcel.

Section 20.13.A.5 Sign Create Visibility Hazard

Construction of a conforming sign would obstruct the vision of motorists or otherwise endanger the health or safety of passers-by.

Section 20.13.A.6 Sign Construction Cause Removal of Physical Element

Construction of a conforming sign would require removal or severe alteration to natural features on the parcel, such as but not limited to: removal of trees, alteration of the natural topography, filling of wetlands, or obstruction of a natural drainage course. A condition of such approval may be that if said tree(s) or obstruction(s) is removed by future development, said signs shall conform to the sign regulatory requirements at that time.

Section 20.13.A.7 Sign Size and Frontage

A sign that exceeds the permitted height or area standards of the ordinance would be more appropriate in scale because of the large size or frontage of the subject parcel or building.

Section 20.14 Application For a Sign Variance

Section 20.14.A Applicant

Any property owner may apply for a variance from the requirements of Article 20: Signs, according to Article 4: Administration and the Variance Application Procedures in Section 4.11: Variance to Section 4.19: General.

Section 20.14.B Burden of Proof

It is the applicant's sole responsibility to prove there is an unnecessary hardship, thus requiring a variance as specified in Section 4.11: Variance to Section 4.19: General.

Section 20.15 Sign Permits

A complete permit application for a sign shall be submitted to the Union Township Zoning Inspector with all applicable fees.

Union Township
Zoning Resolution

Section 20.15.A Application For Sign Permit

An application for a sign shall contain the following information:

Section 20.15.A.1 Applicant's Name

Section 20.15.A.2 Applicant's Mailing Address

Section 20.15.A.3 Applicant's Phone Number

Section 20.15.A.4 Applicant's Fax Number (if applicable)

Section 20.15.A.5 Applicant's E-Mail Address (if applicable)

Section 20.15.A.6 Address of Sign Location

Section 20.15.A.7 Address of property owner where sign is located

Section 20.15.A.8 Letter Signed and Notarized giving the applicant permission to place sign if not on the applicant's property.

Section 20.15.A.9 Sign Structure Height

Section 20.15.A.10 Sign Structure Width

Section 20.15.A.11 Sign Face Height

Section 20.15.A.12 Sign Face Width

Section 20.15.A.13 Sign Type

Section 20.15.A.14 Sign Install Date

Section 20.15.A.15 Sign Removal Date (if applicable)

Section 20.15.A.16 Permit from State (if applicable)

Section 20.15.A.17 A scaled drawing showing the ground elevation, elevation of the highest point of the sign, the height and width of the sign structure, and the height and width of the sign face. For permanent signs, the drawing shall show how the structure is to be anchored to the ground.

Union Township
Zoning Resolution

Section 20.15.A.18 Any additional information as required by the Union Township Zoning Inspector to ensure the proposed sign is compliant with the Union Township Zoning Resolution.

Section 20.15.B Review Period

Upon submittal of an application for a sign permit to the zoning inspector, the zoning inspector shall have thirty (30) days to review and approve or deny said permit.

Union Township
Zoning Resolution

Additional Definitions to be added to the definition section of the Union Township Zoning Resolution:

Temporary Sign: A sign of post and panel construction made of durable materials that is anchored to the ground and braced so that the sign will not sway, flap or otherwise move or be blown out. Said signs are not intended, designed, or permitted for permanent display. Said signs are established for a limited, specified period of time.

Normal Grade: For the purpose of sign height measurements, the term normal grade shall mean the natural grade for undeveloped land, the existing grade for developed land and finished grade for new site development. Said terms are further defined within Appendix A: Definitions of this resolution.

Wall Area Frontage: Shall be defined as that area of the wall of the principal structure that faces a public or private road. For structures that have multiple walls that face the same street, the area of all walls combined as a single wall area calculation to be used in the calculation and/or determination of wall frontage area.

Sign, On-Premise: A sign relating in its subject matter to the single lot of record or multiple lots under the same ownership and use (premises) on which it is located, or to products, accommodations, services, or activities on the premises. On-site signs shall not be construed to include signs erected by the outdoor advertising industry in the conduct of the outdoor advertising business.

Sign, Off-Premise: A sign which directs attention to a business, product, service or entertainment conducted, sold, or offered at a location other than on the lot of record (premises) on which the sign is located.

Non-Residential: For the purpose of this resolution, non-residential shall include any use that is not single-family residential or multi-family residential (duplex, apartments, condominium). Non-residential uses may include commercial, industrial, institutional, agriculture and the like.